

- NOTES: 1. DIMENSIONS A,B,C & D AND SET SCREW SIZE WILL BE DETERMINED BY THE VALVE THAT THE CHAIN BAR IS TO BE USED ON.
 2. SIZE 1/0 GALVANIZED CHAIN WILL BE FURNISHED PER REQUIRED LENGTH.

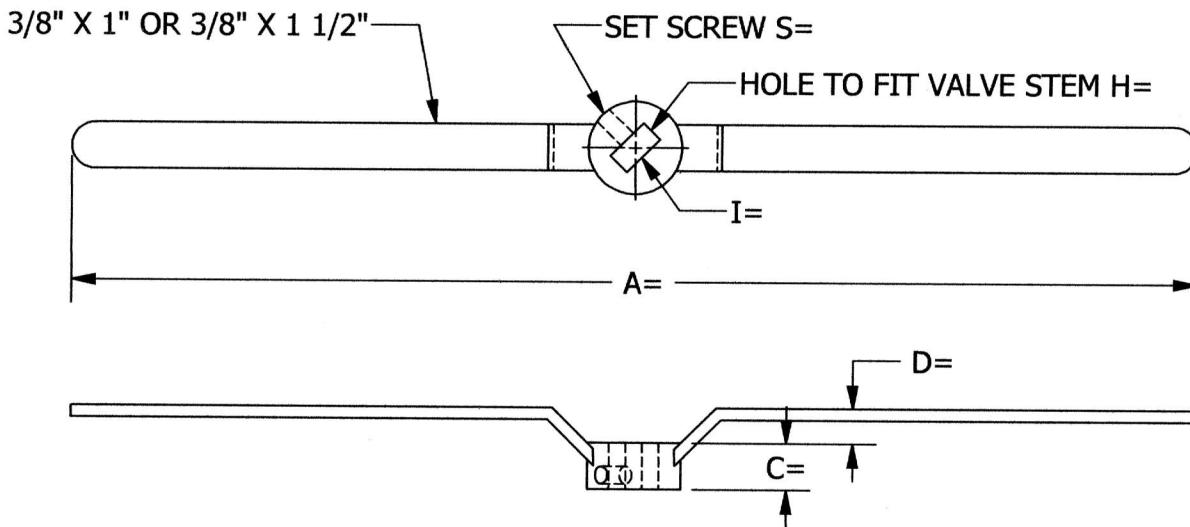

DIMENSIONS REQ'D

A=	
C=	
D=	
H=	
I=	
S=	
Chain Length=	

ROTO HAMMER		
TITLE:		
CHAIN BAR WRENCH CBW-3 OR CBW-6		
SIZE	DWG. NO.	REV
A	RH-125	1
SCALE: NTS WEIGHT:		SHEET 1 OF 1